

GENERAL

Nominal Voltage	51.2V
Working Voltage	43.2V - 58.4V
Recommended Voltage	48.0V - 57.0V
Cells	16
Nominal Capacity	105Ah
Energy	5,376Wh
Reserve @25A	252 Minutes
Self Discharge	1% Per Month
IP Rating	IP65

CHARGING

Recom. Charging Current	<52A
Max Charging Current	105A
Bulk/Absorb Voltage	57.0V
Float Voltage	54.0V or Off
BMS High Voltage Cutoff	59.2V
Charging Temp. Range	34F to 130F

PHYSICAL

Cell Chemistry	Lithium Iron Phosphate
Cell Type	Prismatic
Cell Configuration	1P16S
Series Connectable	No
Parallel Connectable	Yes, up to 2
Weight	94 lbs (42.6Kg)
Dimension LxWxH	13.14"X12.24"X10.15"
Terminal Type	M8 Female
Shell Type	Powder Coated Steel
UN Shipping Class	UN 3480



SAFETY

Charging Freeze Protection	Yes, Under 34F
Pack Over-Voltage	Yes
Cell Balancing	Yes
Pack Under-Voltage	Yes
Cell Under-Voltage	Yes
Cell Over-Temp	Yes
BMS Over-Temp	Yes
Short Circuit/Over Current	Yes
Certifications	UN38.3, UL1642 Cell

DISCHARGING

Max Continuous Discharge	175A
Max Discharge 3 Sec	500A
Max Discharge 30 Sec	300A
Recom. Voltage Cutoff	48.0V
BMS Voltage Cutoff	43.2V
BMS Voltage Recovery	46.4V
Discharge Temp Range	-10F to 140F

COMMUNICATION

Bluetooth	Yes
CAN	Yes

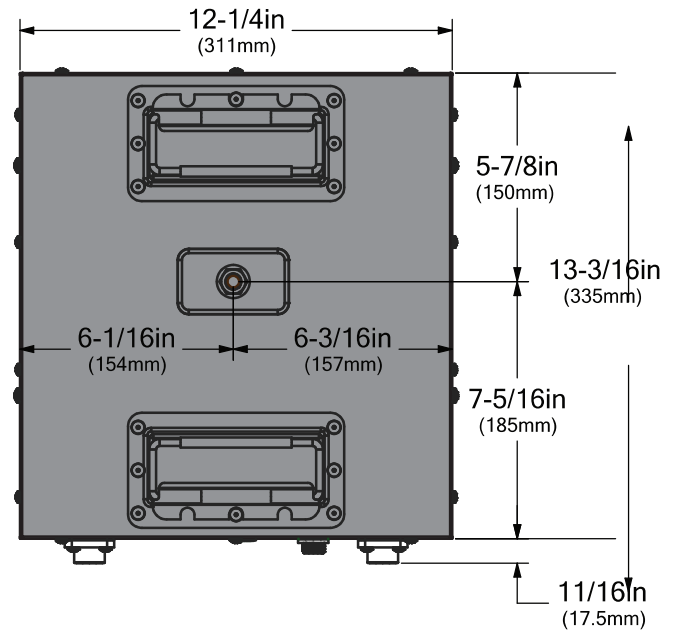

Torque Specs

M8 Terminal Bolts
6ft/lbs (72 in/lbs)

3/8 - 14 Top Mount Nut
10ft/lbs (120 in/lbs)

Voltage Curve

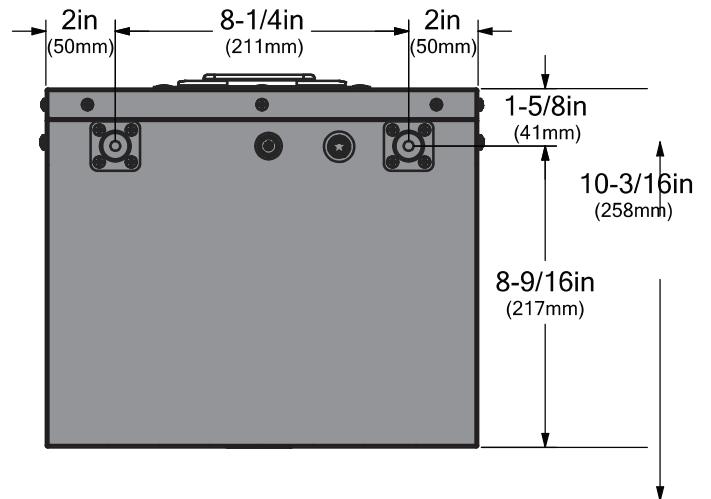
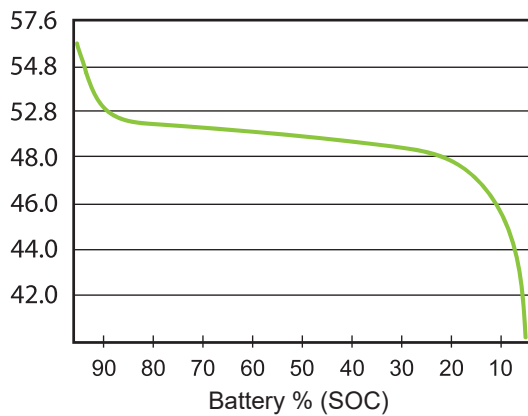



READ BEFORE INSTALL

USE & CARE



HEAVY
TEAM LIFT REQUIRED



HIGH VOLTAGE
HANDLE WITH CARE



DO NOT PRESSURE
WASH OR SUBMERGE



CHARGE BATTERY
BEFORE USE

WARNINGS

- ⚡ High Voltage. DO NOT install or service this battery unless you are properly trained.
- ⚡ Use only with components that have the same voltage and current rating as the battery.
- DO NOT touch or connect to the terminals unless the battery is manually turned off.
- DO NOT open or attempt to service the battery, there are no user serviceable parts inside.

USE & CARE

- Charge the battery daily to ensure it is always fully charged and ready to use.
- Batteries will not charge if the internal battery temperature falls below 34F.
- DO NOT pressure wash, submerge, or use chemical agents to clean your battery.
- Clean the battery using a damp cloth that does not include chemical agents.



For additional product info, user manuals, user guides, and warranty information, please visit <https://ecobattery.com/quickstart> or scan the QR code.