

## GENERAL

Nominal Voltage	51.2V
Working Voltage	43.2V - 58.4V
Recommended Voltage	48.0V - 57.0V
Cell Count	16
Nominal Capacity	105Ah
Energy	5,376Wh
Reserve @25A	252 Minutes
Self Discharge	1% Per Month
IP Rating	IP67

## CHARGING

Recom. Charging Current	<52A
Max Charging Current	105A
Bulk/Absorb Voltage	57.0V
Float Voltage	54.0V or Off
BMS High Voltage Cutoff	59.2V
Charging Temp. Range	32F to 130F

## DISCHARGING

Max Continuous Discharge	175A
Max Discharge 3 Sec	500A
Max Discharge 30 Sec	300A
Recom. Voltage Cutoff	48.0V
BMS Voltage Cutoff	43.2V
BMS Voltage Recovery	46.4V
Discharge Temp Range	-10F to 140F

## COMMUNICATION

Bluetooth	Yes
CAN	Yes



## SAFETY

Charging Freeze Protection	Yes, Under 32F
Pack Over-Voltage	Yes
Cell Balancing	Yes
Pack Under-Voltage	Yes
Cell Under-Voltage	Yes
Cell Over-Temp	Yes
BMS Over-Temp	Yes
Short Circuit/Over Current	Yes
Certifications	UN38.3, UL1642 Cell

## PHYSICAL

Cell Chemistry	Lithium Iron Phosphate
Cell Type	Prismatic
Cell Configuration	1P16S
Series Connectable	No
Parallel Connectable	Yes, up to 2
Weight	102.2 lbs (46.3Kg)
Dimension LxWxH	22"X9.75"X10.43"
Terminal Type	M8 Female
Shell Type	Powder Coated Steel
UN Shipping Class	UN 3480

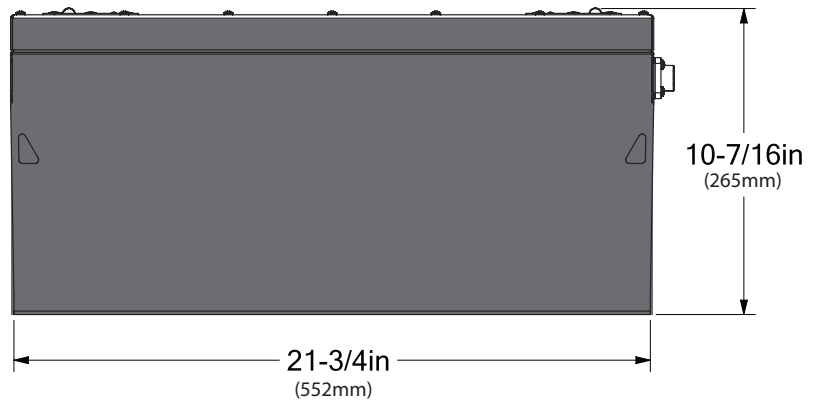
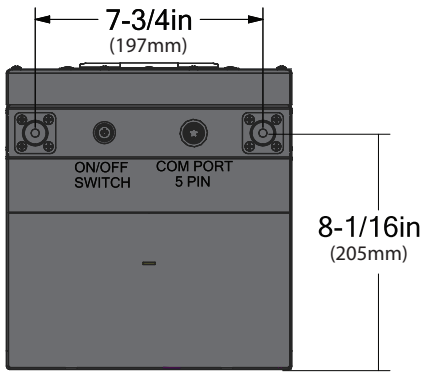
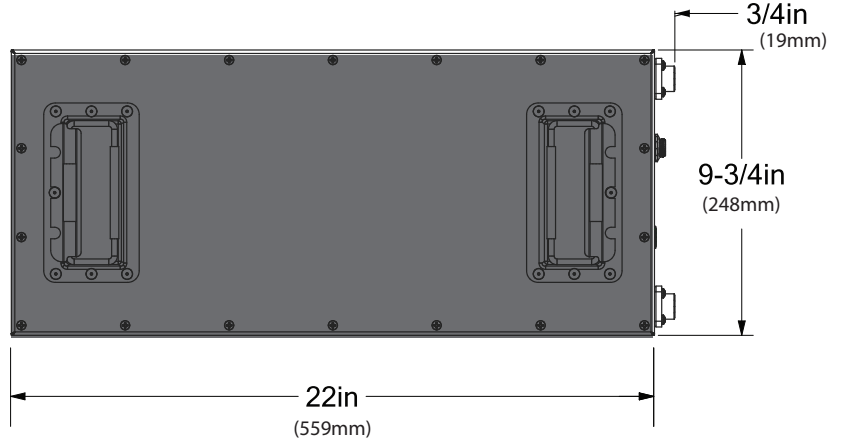

**Torque Specs**  
M8 Terminal Bolts - 6ft/lbs (72 in/lbs)

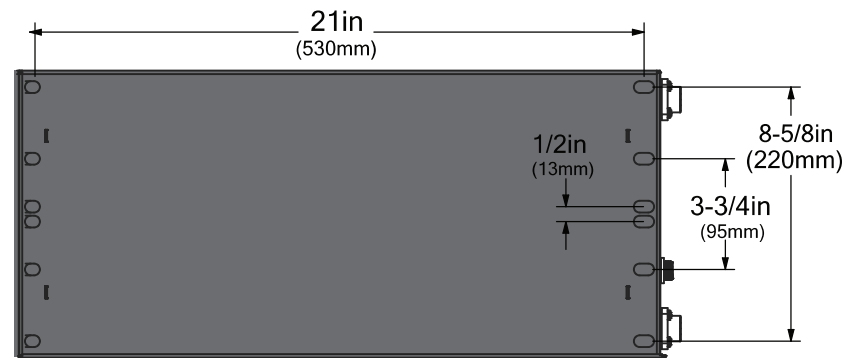
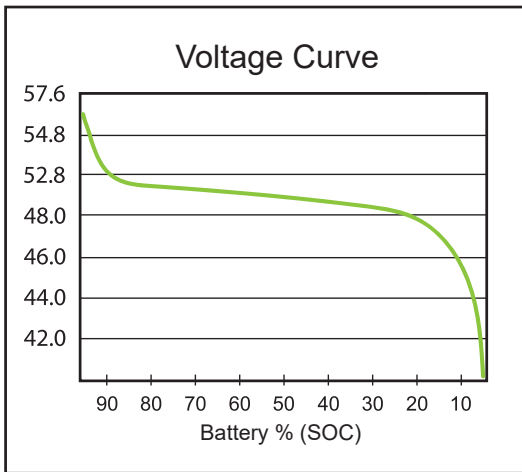



# READ BEFORE INSTALL

## USE & CARE



HEAVY  
TEAM LIFT REQUIRED



HIGH VOLTAGE  
HANDLE WITH CARE



DO NOT PRESSURE  
WASH OR SUBMERGE



CHARGE BATTERY  
BEFORE USE

## WARNINGS

- ⚡ High Voltage. DO NOT install or service this battery unless you are properly trained.
- ⚡ Use only with components that have the same voltage and current rating as the battery.
- DO NOT touch or connect to the terminals unless the battery is manually turned off.
- DO NOT open or attempt to service the battery, there are no user serviceable parts inside.

## USE & CARE

- Charge the battery daily to ensure it is always fully charged and ready to use.
- Batteries will not charge if the internal battery temperature falls below 34F.
- DO NOT pressure wash, submerge, or use chemical agents to clean your battery.
- Clean the battery using a damp cloth that does not include chemical agents.



For additional product info, user manuals, user guides, and warranty information, please visit <https://ecobattery.com/quickstart> or scan the QR code.